

Planet Fingerschutz FSR 5000 [BASIC]

ASSA ABLOY

DE Montageanleitung

EN Installation instructions

FR Instructions de montage

ES Instrucciones de montaje

IT Istruzioni di montaggio

D0140200, 04.2025 901361

Experience a safer
and more open world

DE Lesen Sie diese Anleitung vor der Benutzung sorgfältig durch und bewahren Sie sie auf.

EN Read this manual carefully prior to use and keep it safe for later reference.

FR Lisez attentivement cette notice d'instructions avant l'utilisation du produit et conservez-la soigneusement.

Verwendungszweck

Planet Fingerschutz FSR wird an Türen montiert zur Sicherung der Gegenbandseite an der Nebenschliesskante.

Intended use

Planet finger protection FSR is fitted on doors to protect the push side on the side closing edge.

Emploi prévu

Les protections des doigts FSR Planet sont montés dans les portes pour fixer le coté de la charnière contre à la clôture secondaire.



Vorsicht!

Aufsichtspflicht: Der Einsatz von Planet Fingerschutz entbindet nicht von der Aufsichtspflicht.



Caution!

Duty of supervision: The use of Planet finger protection does not release the user from the duty of supervision.



Prudence !

Obligation de surveillance: L'utilisation de la protection des doigts Planet ne dégage pas de l'obligation de surveillance.

ES Lea detenidamente estas instrucciones antes de utilizar el producto y consérvelas para futuras consultas.

IT Prima dell'uso, leggere attentamente le presenti istruzioni e conservarle.

Finalidad de su utilización

La protección para dedos FSR Planet se instala en puertas para proteger el lado de la contrabisaagra en el borde de cierre secundario.

Uso

La protezione salvadita Planet FSR viene montata sulle porte per proteggere il lato opposto cerniere in corrispondenza del bordo di battuta.



¡Precaución!

Deber de vigilancia: El uso de la protección para dedos Planet no le exime de su deber de vigilancia.



Cautela!

Obbligo di sorveglianza: L'uso della protezione salvadita Planet non esonera dall'obbligo di sorveglianza.

A

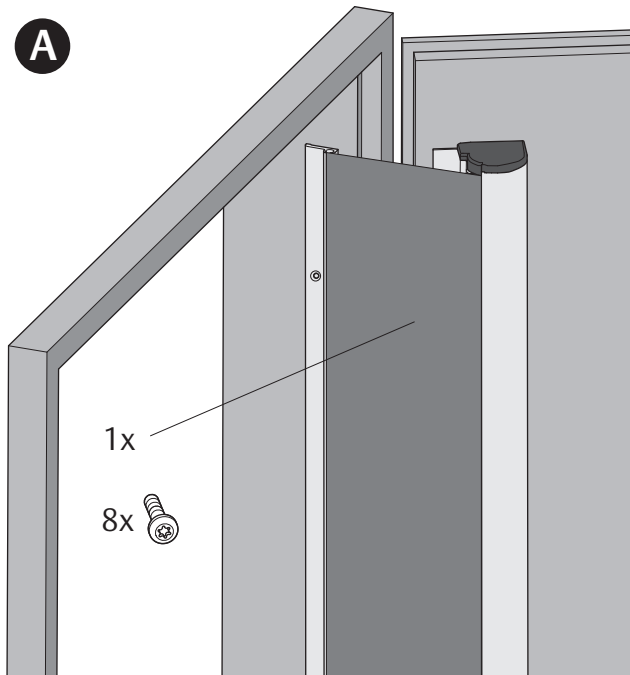

B1

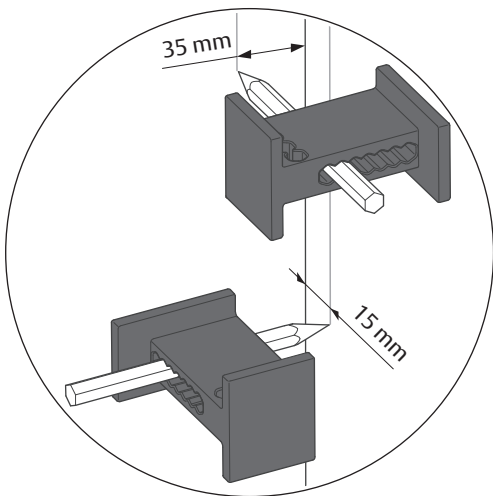
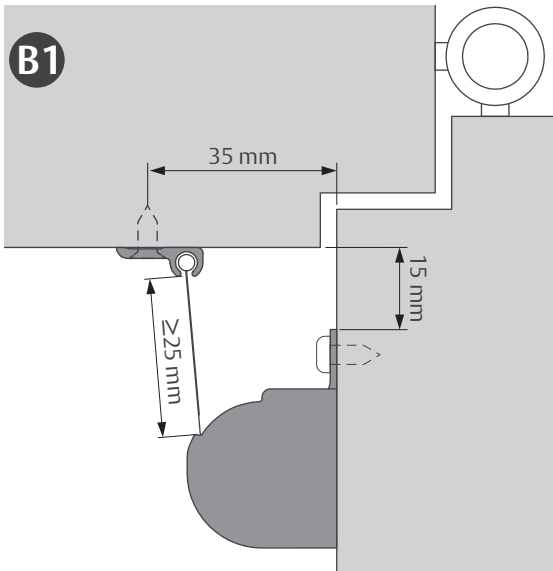

B2

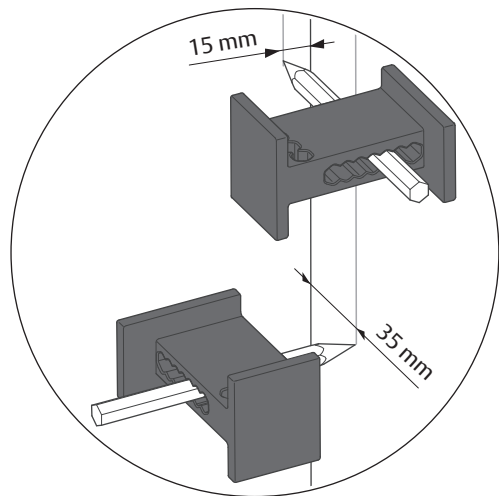
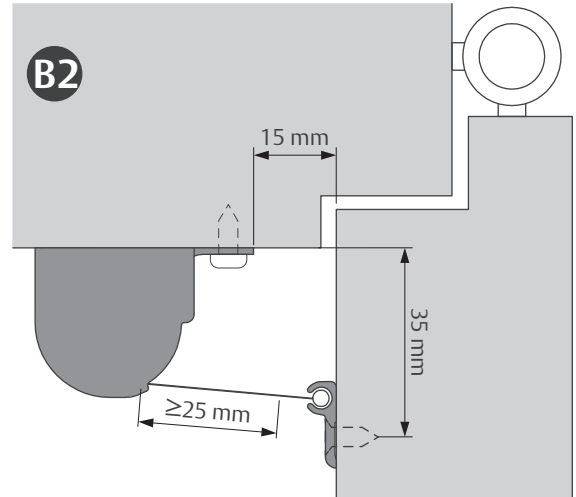

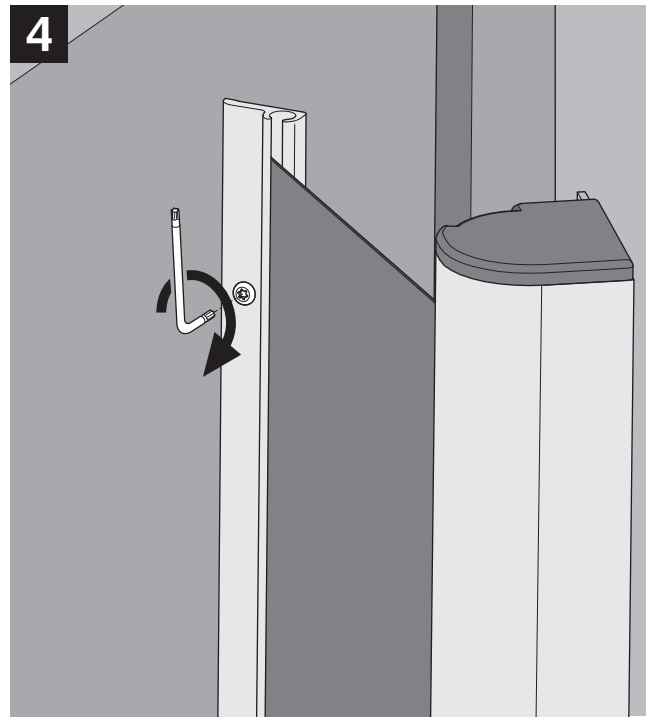
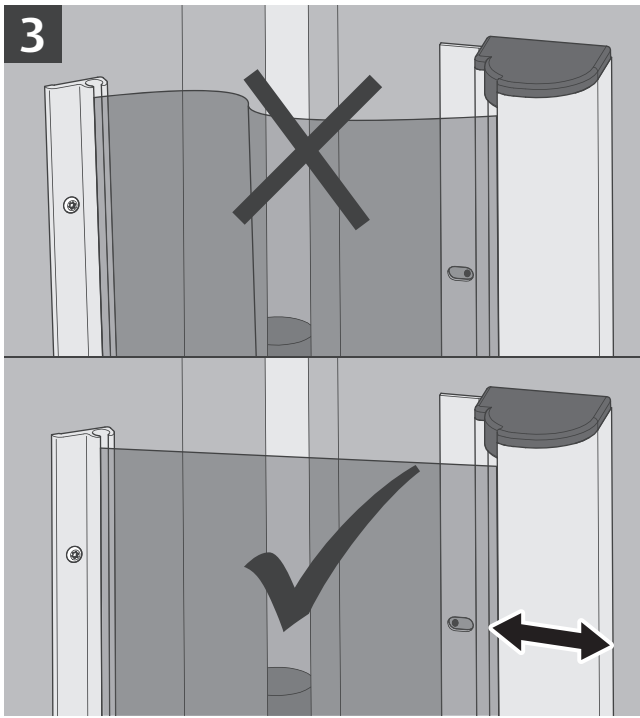
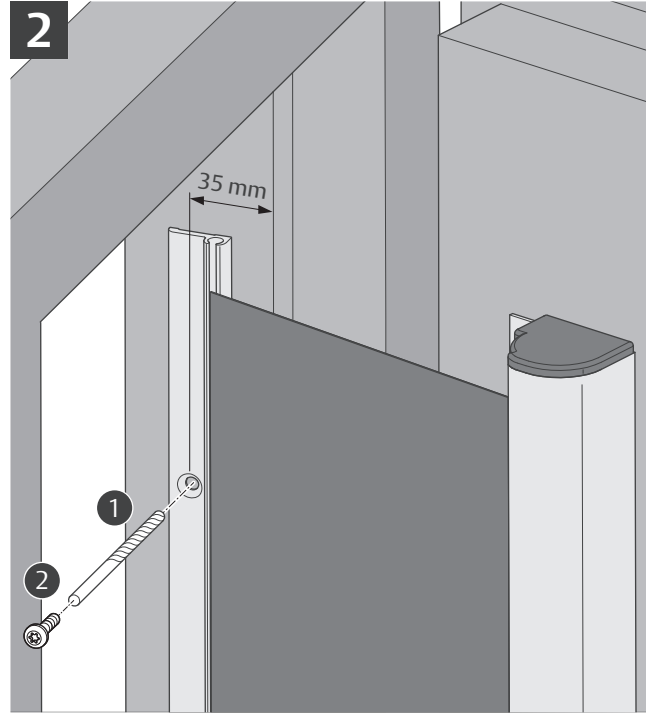
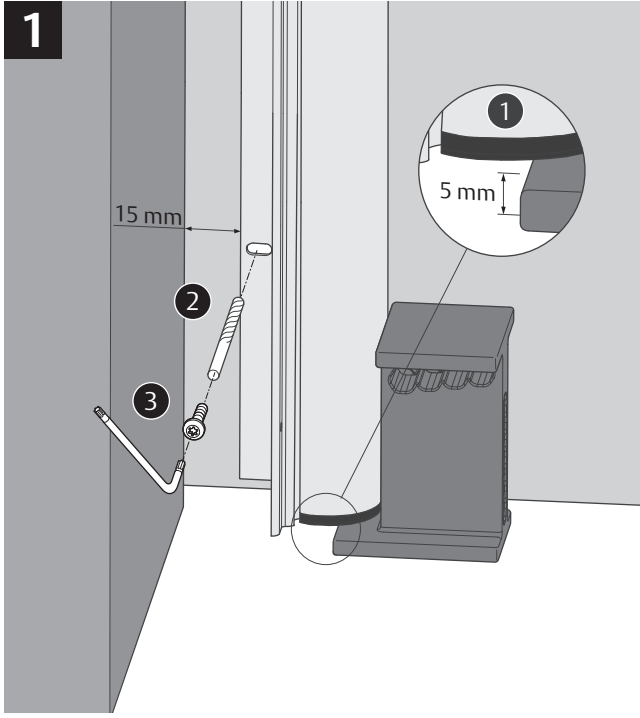

DE**Wartung**

Alle zwei Jahre auf Funktion und Verschmutzung prüfen, falls nötig reinigen.

Entsorgung

Planet Fingerschutz nach Materialart zerlegen und recyceln. Beachten Sie die gesetzlichen Vorschriften in Ihrem Land.

Mehr Informationen unter

www.planet.ag

EN**Maintenance**

Check every two years for function and dirt, clean if necessary.

Recycling

Take apart and recycle Planet finger protection according to material type. Follow the regulations in your country.

For more information

www.planet.ag

FR**Entretien**

Examiner tous les 2 ans le fonctionnement et l'encrassement, nettoyer si nécessaire.

Recyclage

Démonter et recycler la protection des doigts Planet suivant le type de matériau. Suivre les prescriptions du pays.

De plus amples renseignements sous

www.planet.ag

ES**Mantenimiento**

Comprobar el funcionamiento y el grado de suciedad cada dos años; limpiar en caso necesario.

Reciclaje

Desmontar y reciclar la protección para dedos Planet conforme al tipo de materiales. Tenga en cuenta las normativas legales de su país.

Más información

www.planet.ag

IT**Manutenzione**

Controllare ogni due anni il funzionamento e la presenza di sporco; se necessario, pulire.

Smaltimento

Smontare e riciclare la protezione salvadita Planet in base al tipo di materiale. Rispettare le disposizioni di legge in vigore nel proprio Paese.

Per saperne di più, visitare

www.planet.ag

DE**Zubehör**

Zur vollständigen Absicherung der Nebenschließkante gehört auch immer die Absicherung der Bandseite. Dazu empfehlen wir unsere bandseitigen Schutzprofile, welche für alle Bandtypen passen.

EN**Accessories**

Complete protection of the side closing edge also invariably involves protection of the hinge side. We therefore recommend our hinge protection profiles, which are suitable for all hinge types.

FR**Accessoire**

La protection du côté paumelle est toujours nécessaire pour la protection intégrale de l'arête de fermeture secondaire. Pour cela, nous vous recommandons nos profilés de protection pour côté paumelle qui conviennent à tous les types de paumelles.

ES**Accesorios**

En la protección completa del borde de cierre secundario se incluye también siempre la protección de la cara de la bisagra. Para ello recomendamos emplear nuestros perfiles protectores, aptos para todo tipo de bisagras, en el lado de la bisagra.

IT**Accessori**

La protezione completa del bordo di battuta include sempre anche la protezione del lato cerniera. A tale scopo consigliamo i nostri profili di protezione lato cerniera, adatti a tutti i tipi di cerniera.

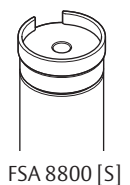
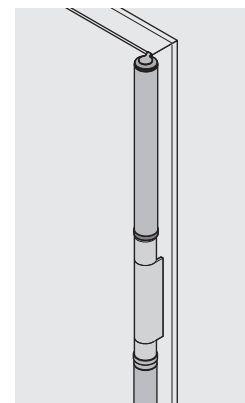

FSA 8800 [S]

ASSA ABLOY (Schweiz) AG
Absenkdichtungen & Fingerschutz
Untere Schwandenstrasse 22
8805 Richterswil
SWITZERLAND
Tel. +41 (0) 43 266 22 22
mail.planet@assaabloy.com
www.planet.ag



ASSA ABLOY
Opening Solutions