



CERTIFICATE OF APPROVAL

No CF 5033

This is to certify that, in accordance with
TS00 General Requirements for Certification of Fire Protection Products
The undermentioned products of

ASSA ABLOY LIMITED T/A LORIENT

Portobello Works, School Street, Willenhall, WV13 3PW, United Kingdom

Tel: 01626 834252 Fax: 01626 833166

Have been assessed against the requirements of the Technical Schedule(s)
denoted below and are approved for use subject to the conditions
appended hereto:

CERTIFIED PRODUCT

Lorient Polyproducts
'RF1' - 'Rigid Figure 1' Glazing
System

TECHNICAL SCHEDULE

TS25 Fire Resistant Glass,
Glazing Systems and Materials

Signed and sealed for and on behalf of Warringtonfire Testing and Certification Limited

Paul Duggan
Certification Manager



Issued:
Revised:
Valid to:

14th March 2012
2nd March 2023
29th January 2028





CERTIFICATE No CF 5033

ASSA ABLOY LIMITED T/A LORIENT

LORIENT POLYPRODUCTS 'RIGID FIGURE 1' GLAZING SYSTEM

This Certificate of Approval relates to the contribution to fire resistance of the Lorient 'Rigid Figure 1' Glazing System when used in timber door leaves and glazed screens, for periods of 60 minutes integrity (and insulation depending on glass specification), as defined in BS 476: Part 22: 1987 subject to the undermentioned conditions.

This certification is provided to the client for their own purposes and we cannot opine on whether it will be accepted by Building Control authorities or any other third parties for any purpose.

This product is approved on the basis of:

- a) Initial type testing
- b) A design appraisal against TS25
- c) Certification of quality management system to BS EN ISO 9001: 2008
- d) Inspection and surveillance of factory production control
- e) Audit Testing in accordance with TS25

This Certificate of Approval must be read in conjunction with CERTIFIRE Technical Schedule TS25, Fire Resistant Glass, Glazing Systems and materials.

Lorient Polyproducts 'Rigid Figure 1' Glazing System

Lorient Polyproducts 'Rigid Figure 1' Glazing System consists of the following essential elements:

- a) Sodium silicate intumescent encapsulated in rigid PVC with functional flexible fins
- b) Hardwood* retaining beads of a specific design and min. density 610 kg/m³
- c) Pin or screw fixings, via the retaining beads
- d) A secondary sodium silicate based intumescent material used as a lining around the perimeter of the aperture to be glazed

The system is used at the perimeter of a pane of fire resisting glass to provide an effective seal between the glass and substrate within a door leaf or timber screen.

* excluding Ash and Beech.

CERTIFICATE No CF 5033 ASSA ABLOY LIMITED T/A LORIENT

LORIENT 'RIGID FIGURE 1' GLAZING SYSTEM WITHIN 60 MINUTE TIMBER DOORSETS

The figure below shows the relevant dimensions of the 'Rigid Figure 1' Glazing System and basic glazing details within timber based door leaves:

Figure 1 opposite shows a typical arrangement of Lorient 'Rigid Figure 1' Glazing System in a timber door leaf. The system may be used with either 50 mm long pins or screws at maximum 150 mm fixing centres.

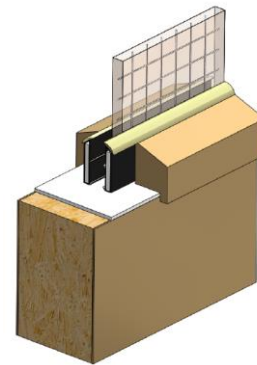

Figure 1.

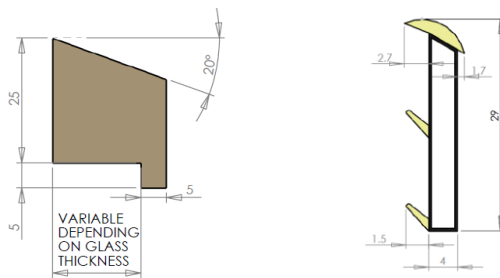

Figure 2.

Figure 2 shows the required glazing bead for Lorient 'Rigid Figure 1' Glazing System. The bead should be hardwood* and minimum density 610 kg/m³. Depth of rebate will vary depending on thickness of glass being used. The angle on top of the bead may be from 17° to 20°. The "nib" which overhangs may be a minimum of 5mm by 5mm with no restriction on the maximum dimension.

* excluding Ash and Beech

Figure 3 includes details relating to the use of the 'Rigid Figure 1' glazing system within door leaves showing the 2 mm sodium silicate intumescent liner which shall be used to line the aperture.

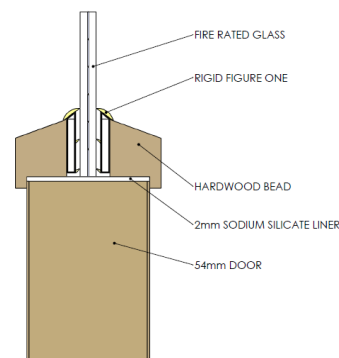

Figure 3.

CERTIFICATE No CF 5033 ASSA ABLOY LIMITED T/A LORIENT

LORIENT 'RIGID FIGURE 1' GLAZING SYSTEM WITHIN 60 MINUTE TIMBER DOORSETS

This Certificate of Approval relates to the following glasses when used in conjunction with a 'Rigid Figure 1' Glazing System at the maximum sizes shown in Table 1 below:

Glass	Fire Performance - Integrity/Insulation (minutes)	Maximum Pane Height (mm)	Maximum Pane Width (mm)	Maximum Pane Area (m ²)
Pyroshield 2	60/0	1488	620	0.75
Firelite	60/0	1488	620	0.75
Pyran S (6, 8, 10 and 12 mm)	60/0	1488	620	0.75
Pyrobelite 12	60/0	1488	620	0.75
Pyroguard C/W 11.4mm	60/0	1400	460	0.575
Pyranova 15-S2.0/S2.1	60/0	1770	590	0.885
Pyranova 30 – S3.0	60/30	1770	590	0.885
Pyrostem (7 mm)	60/0	1488	620	0.75
Pyrobel 16	60/30	1488	620	0.75
13 mm Pyrodur 60-20	60/0	1488	620	0.75
15 mm Pyrostop 30-10	60/30	1488	620	0.75
Pyroguard Insulation '30-15'	60/30	1440	540	0.65

Table 2 - Acceptable Glass Dimensions

This Certificate of Approval relates to timber based door leaf constructions consisting of timber faces coupled with timber or other cellulosic cores of not less than 54 mm overall leaf thickness.

A secondary 2 mm thick sodium silicate based intumescent material to the full width of the leaf is required to be used as a lining around the perimeter of apertures.



CERTIFICATE No CF 5033

ASSA ABLOY LIMITED T/A LORIENT

The 'Rigid Figure 1' Glazing System may be fitted in the manner described in this Certificate of Approval, to previously tested door leaves provided that the particular aspects of the door assembly are maintained. These are described below but are not exhaustive:

1. The doorset, including door frame and associated building hardware, should have achieved at least 60 minutes integrity when tested or subsequently assessed by one of the laboratories approved by CERTIFIRE as acceptable for this purpose to BS 476: Part 22: 1987.
2. If the proposed doorset is to be used in double-leaf configuration, the test or assessment evidence should be applicable to double-leaf configurations.
3. Likewise, if the proposed doorset is to be used in the unlatched configuration the available evidence should be applicable to unlatched doorsets.
4. The proposed doorset should also have included a glazed aperture or apertures of the intended size, shape, area and number.
5. When used to glaze CERTIFIRE approved doorsets which have smaller apertures than allowed in this certificate, the aperture sizes specified in the doorset certificate shall take precedence.

In this way the proposed installation of the Lorient Polyproducts 'Rigid Figure 1' Glazing System is not expected to affect the fire resistance performance of the leaf.

CERTIFICATE No CF 5033 ASSA ABLOY LIMITED T/A LORIENT

LORIENT 'RIGID FIGURE 1' GLAZING SYSTEM WITHIN 60 MINUTE TIMBER SCREENS

Figure 4 shows a typical arrangement of Lorient 'Rigid Figure 1' in a timber screen. The glazing systems may be used with either pinned or screw-fixed retaining beads, 50 mm long at 150 mm maximum centres.

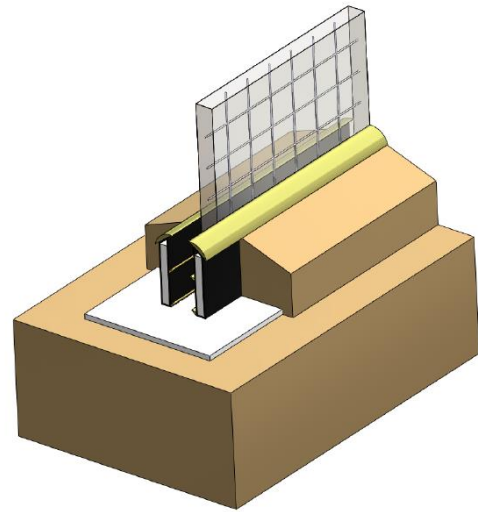

Figure 4.

Figure 5 shows the tested dimensions for framing members, as manufactured from hardwood with a minimum density of 610kg/m^3 , including a 2 mm sodium silicate liner. 2 mm deep rebate in bottom of bead may vary in width depending on glass thickness. The angle on top of the bead may be from 17° to 20° .

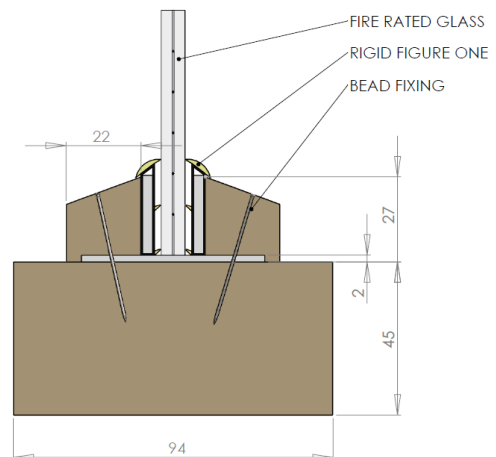

Figure 5.



CERTIFICATE No CF 5033
ASSA ABLOY LIMITED T/A LORIENT

LORIENT 'RIGID FIGURE 1' GLAZING SYSTEM WITHIN 60 MINUTE TIMBER SCREENS

This Certificate of Approval relates to the following glasses when used in conjunction with Lorient 'Rigid Figure 1' Glazing systems at the maximum sizes shown in Table 2 below:

Table 2 - Acceptable glass sizes for screens

Glass	Fire Performance - Integrity/Insulation (minutes)	Maximum Pane Height (mm)	Maximum Pane Width (mm)	Maximum Pane Area (m ²)
Pyroshield 2	60/0	1488	620	0.75
		500	1000	0.5
Firelite	60/0	1488	620	0.75
		500	1000	0.5
Pyran S (6, 8, 10, 12 mm)	60/0	1488	620	0.75
		500	1000	0.5
Pyrostem (7 mm)	60/0	1488	620	0.75
		500	1000	0.5
13 mm Pyrodur 60-20	60/0	1488	620	0.75
		500	1000	0.5
15 mm Pyrostop 30-10	60/30	1488	620	0.75
		500	1000	0.5
Pyroguard C/W 11.4mm	60/0	1400	460	0.575
Pyranova 15-S2.0/S2.1	60/0	1770	590	0.885
		500	1000	0.5
Pyranova 30-S3.0	60/30	1770	590	0.885
		500	1000	0.5
15 mm Pyrostop 30-10 and 18 mm Pyrostop 30-20	60/30	1488	620	0.75
		500	1000	0.5
Insulating Glass Units (IGU's) including 15 mm Pyrostop 30-10 and 18 mm Pyrostop 30-20	60/30	1488	620	0.75
		500	1000	0.5

Page 7 of 8 Signed:
E/108

Issued: 14 March 2012
Revised: 2nd March 2023
Valid to: 29th January 2028

CERTIFICATE No CF 5033 ASSA ABLOY LIMITED T/A LORIENT

Table 2 (continued) - Acceptable glass sizes for screens

Glass	Fire Performance – Integrity/Insulation (minutes)	Maximum Pane Height (mm)	Maximum Pane Width (mm)	Maximum Pane Area (m ²)
23 mm Pyrostop 60-101	60/60	1488	620	0.75
		500	1000	0.5
Insulating Glass Units (IGU's) including 23 mm Pyrostop 60-101	60/60	1488	620	0.75
		500	1000	0.5
Pyrobelite 12	60/0	1488	620	0.75
		500	1000	0.5
Pyrobel 16	60/30	1488	620	0.75
		500	1000	0.5
Pyrobel 25	60/60	1488	620	0.75
		500	1000	0.5
IGU Pyroguard 11 mm Clear or Wired Glass, 12mm steel spacer and 4 mm float glass	60/0	1488	620	0.75
		500	1000	0.5
Pyroguard Insulation '30-15'	60/30	1488	620	0.75
		500	1000	0.5
Pyroguard Insulation '60-23'	60/60	1488	620	0.75
		500	1000	0.5

The above table applies to hardwood framed screens, including multi-paned assemblies with shared mullions and transoms and sidelights/overpanels to doorsets.