



Fire and Smoke Resistant Dampers / Air Transfer Grilles

A photograph of a modern, multi-story glass building at night. The building's facade is composed of large glass panels and dark metal frames. The interior lights are on, creating a warm glow that is visible through the windows. The sky is dark, and the overall scene is illuminated by the building's lights and some ambient light.

high performance
fire containment & air transfer



Fire and smoke protection measures are essential, life-saving precautions in a building. What's more, they protect the property from the devastating consequences of the fire itself, and the damaging effects of hot and cold smoke. So it's essential to get the product selection right, every time.

Lorient has a respected reputation for designing and manufacturing a wide range of products for fire and smoke containment. Products are also designed with acoustic, thermal and weather containment in mind, as well as accessibility – so you can be assured that a Lorient system provides an integrated, cost-effective solution.

With over 35 years' experience and accumulated knowledge, we pride ourselves on offering ground-breaking innovations, underpinned by technical excellence and exceptional quality. Our dedicated R&D centre not only generates successful product developments for Lorient; it also allows us to work in partnership with customers to develop and test their own products too. Our indicative fire test furnace is particularly popular, giving customers real insight into their own products' performance and helping to save substantial testing costs.

Always keen to keep raising the bar, we are committed to gaining third party certification for our products wherever a suitable scheme exists. Many products hold CERTIFIRE certification, and we also hold approvals from both the BBA and IFC.

We embrace the highest management standards too, and hold both BS EN ISO 9001:2008 and BS EN ISO 14001:2004 certificates for our quality and environmental management systems. Achieving ISO 14001 is just one part of our ongoing commitment to operate in a sustainable way: many initiatives are planned and already underway to reduce materials and energy usage, as well as waste.

In addition to our UK and Europe head office, we have a number of operations around the world; in North America, Hong Kong, Singapore, Dubai and Australia. Furthermore, we have strong links in India, which means that we're able to deliver the right solutions locally to our customers throughout the world. By keeping abreast of technical developments and changes to codes, regulations and standards across the continents, we can ensure we're always providing the highest level of expertise. From advice to testing, new product development to manufacture – we work best in partnership with you.

Contents

| | |
|---|---------|
| Fire and Smoke - Life Threatening Forces | 2 |
| Ventilation with Fire and Smoke Protection | 3 |
| Fire and Smoke Resistant Dampers / Air Transfer Grilles System Benefits | 3 |
| Product Range | 4 - 5 |
| Operation | 6 |
| Lorient Smoke Control Systems | 6 - 8 |
| Product Solutions | 9 - 18 |
| - Doors | 13 - 14 |
| - Walls | 15 |
| - Floors & Ceilings | 16 |
| - Ducts | 17 - 18 |
| Sealant | 19 |
| Finishes | 19 |
| Additional Information | 19 |
| Comprehensive Support | 20 - 21 |

Fire and Smoke – Life Threatening Forces

On average **322 people are killed** and **9,748 are injured*** in fires each year in the UK alone. Many of the casualties are attributable to breathing the toxic products of combustion from a remote fire.

Fire and smoke also cause extensive damage to building fabric and contents. **£2.52 billion*** per annum is the estimated total of fire-related losses. The majority of these deaths, injuries and losses occur in buildings where fire and smoke protection measures have been inadequate.

Design Needs and Regulatory Requirements

When fire breaks out in a building the threat is twofold. Firstly, there is the fire itself and the hot smoke generated in the immediate vicinity. Secondly, there is cold smoke which will spread rapidly through the building, threatening people and property some distance from the fire. The Building Regulations take both these threats into account, and supporting documents give criteria for how they can be managed.

Details can be found in Approved Document B (England & Wales), Technical Booklet E (N Ireland), and Technical Handbook Section 2 (Scotland).

The Regulations require large buildings to be divided into smaller fire and smoke resistant 'compartments', to reduce the risk of damage to the building as a whole and also to save lives in the case of a fire. Building a fire resistant wall or floor to make a compartment is relatively simple. However, building design becomes much more complex when the compartments need to be linked in some way – essential to make the building usable. Every time an aperture is cut into one of the compartment boundaries (for example, to install a door in a fire resistant wall, or to pass ductwork through a wall or ceiling) the aperture must be filled with something that will preserve the fire and smoke integrity of the compartment. That's the role of Lorient's products – to work with the surrounding elements of the building to preserve the integrity of the fire and smoke resistant compartments. Our fire and smoke seals can be fitted into fire rated doors; our glazing products can be fitted into doors, screens or fire rated partitions; our air transfer grilles can be installed into doors, walls and ducts.

Fire and smoke protection products must be tested to prove their performance, and indeed, separate tests are required for fire and smoke. Our products are all extensively tested, and our test reports are freely available on request. Just call our Technical Services team on **01626 834252**.

Dampers / Air Transfer Grilles

The Lorient solution is to fit fire containment air transfer grilles at the point of penetration. Under normal circumstances these allow air to pass freely between compartments. In the event of fire the slats and framing components swell to many times their original thickness, fusing together to form a non-combustible mass which provides fire resistance to match the surrounding construction and prevents the passage of hot smoke and gases. The fire containment air transfer grilles contain no moving parts which results in low maintenance.

The Lorient range of intumescent air transfer grilles combined with automatic smoke control systems provides protection against cold smoke. These electrically powered dampers are connected to a standard smoke or fire alarm/detection system which, when triggered, causes the dampers to close thereby preventing the passage of cold smoke. Under normal circumstances the dampers remain open allowing the free passage of air.



Relevant Requirements

There are several British Standards which relate to the products and solutions featured in this brochure. They include:

- BS 476: Section 31.1: 1983: Methods for measuring smoke penetration through doorset and shutter assemblies;
- BS 476: Pt. 22: 1987: Methods for determination of the fire resistance of non-loadbearing elements of construction;
- BS ISO 10294-5:2005: Fire-resistance tests. Fire dampers for air distribution systems. Intumescent fire dampers;
- BS EN 1634-1: 2008: Fire resistance and smoke control tests for door, shutter and, openable window assemblies and elements of building hardware. Fire resistance tests for doors, shutters and openable windows;
- BS 9999: 2008: Code of practice for fire safety in the design, management and use of buildings.

*Source: Communities and Local Government Website, 2015.

Ventilation with Fire and Smoke Protection

Designers recognise the need for buildings to be well ventilated for the health and comfort of occupants. Frequent changes of air flush out airborne infections, and warm and cool air need to be circulated to maintain comfortable temperatures.

Ventilation through Doors, Walls, Floors & Ceilings

A study of regulatory requirements reveals that nearly all internal fire resistant doors (and, therefore, the walls in which they are located) also need to provide protection against cold smoke. Any steps taken to allow ventilation through such walls and doors must not allow the passage of cold smoke in the event of fire.

The common practice of undercutting the door in the belief that the threshold is a low risk area has now been totally discredited. It creates a major smoke hazard. Similarly, fitting a conventional grille to a wall or door will totally negate other measures taken to prevent the spread of fire, hot smoke and cold smoke.

Lorient intumescent air transfer grilles and automatic smoke control systems provide protection against fire, hot smoke and cold smoke.

Ventilation through Ducting

Experience has shown that ducting can, in the event of fire, provide a conduit for fire, hot smoke and cold smoke. An intumescent fire damper, fitted into the duct at the point where it penetrates a fire resistant construction, will prevent the passage of fire and hot smoke. Lorient intumescent fire dampers fitted in conjunction with a Lorient automatic smoke control system will also provide protection against cold smoke. They have been shown by specific testing to be equivalent to a conventional damper, not only in fire

and smoke barrier properties but also by exhibiting insulation values.

Lorient fire resistant dampers / air transfer grilles can be:

- factory fitted in a tested fire resisting doorset
- “retro fit” to an already installed fire door
- fitted in fire resisting walls, partitions, floors and ceilings
- installed in duct work (LVC40, LVH44, LVHC44 and LVH54).

Fire and Smoke Resistant Dampers / Air Transfer Grilles



System features include:

- A comprehensive range of dampers / air transfer grilles providing protection against fire and smoke at all temperatures
- Test evidence second to none
- Fire performance ratings from 30 minutes to in excess of 180 minutes
- Fully tested for smoke performance
- Products for all applications - doors, walls, ducts, floors & ceilings
- Low maintenance
- Co-ordinated with other Lorient products and ironmongery.

Product Range

Listed below are the features and attributes of each product in the Lorient damper / air transfer grille range. Further information on the products, including sizes, shapes and finishes, can be found on pages 10 and 11.

Application details and additional performance information can be found on pages 13 to 18.



Non-vision Style **LVN20 and LVN25**

- can be used to provide up to 60 minutes resistance to fire and hot smoke
- angled slats ensure complete visual privacy
- supplied in two halves to accommodate different door thicknesses
- complete seal achieved in approximately five minutes when tested in accordance with BS 476: Pts. 20 & 22
- allows bi-directional air flow
- easy to keep clean
- contain no moving parts
- no site testing is necessary.

Vision Style **LVV40 and LVC40**

- can be used to provide up to 60 minutes resistance to fire and hot smoke
- excellent airflow characteristics which result in silent efficient operation in normal use
- complete seal achieved in approximately five minutes when tested in accordance with BS 476: Pts. 20 & 22 and BS EN 1634-1: 2000
- allows bi-directional air flow
- simple to install
- no maintenance required
- contain no moving parts
- resistant to clogging.



High Performance Vision Style **LVH44** and **LVHC44**

Lorient LVH high performance grilles are manufactured using Z275 grade galvanised steel, suitable for external applications. Additionally, the surfaces of fixing points are treated with a corrosion resistant coating, giving them a highly durable finish.

- can be used to provide up to 180 minutes resistance to fire and hot smoke
- complete seal achieved in approximately 2 minutes when tested in accordance with BS 476: Pts. 20 & 22 and BS EN 1634-1: 2000
- exhibit excellent airflow characteristics and give silent efficient operation with normal to high air velocities
- can be used in ducting where the steel and aluminium casing protects the intumescent material from the corrosive effect of hot gases travelling at high velocities
- can be used to provide up to 180 minutes fire resistance
- has a galvanised steel frame which contributes to fire resistance by preventing the inward deformation of surrounding structures thus protecting the intumescent materials
- resistant to vibration damage
- suitable for horizontal and vertical applications
- suitable for external applications
- low maintenance
- contain no moving parts.



CF564

Duct Damper **LVH54**

- has been specifically designed to meet the tough requirements of BS ISO 10294 Pt. 5
- forms a complete seal within 2 minutes
- can withstand a 300P pressure differential across the damper
- maintains its fire integrity for a period of four hours
- has a galvanised steel frame and stainless steel slat, which is ideal for harsh duct environments, including high humidity
- suitable for vertical applications
- low maintenance
- contain no moving parts.

Operation - Vision, Non-vision and High Performance Styles

Lorient fire containment air transfer grilles / dampers are made up of either PVC or metal slats with an intumescent core.

A sudden increase in temperature resulting from the presence of flames or hot gases causes the slats and framing components to swell to many times their original thickness, fusing together to provide an effective barrier to the passage of fire and hot smoke.

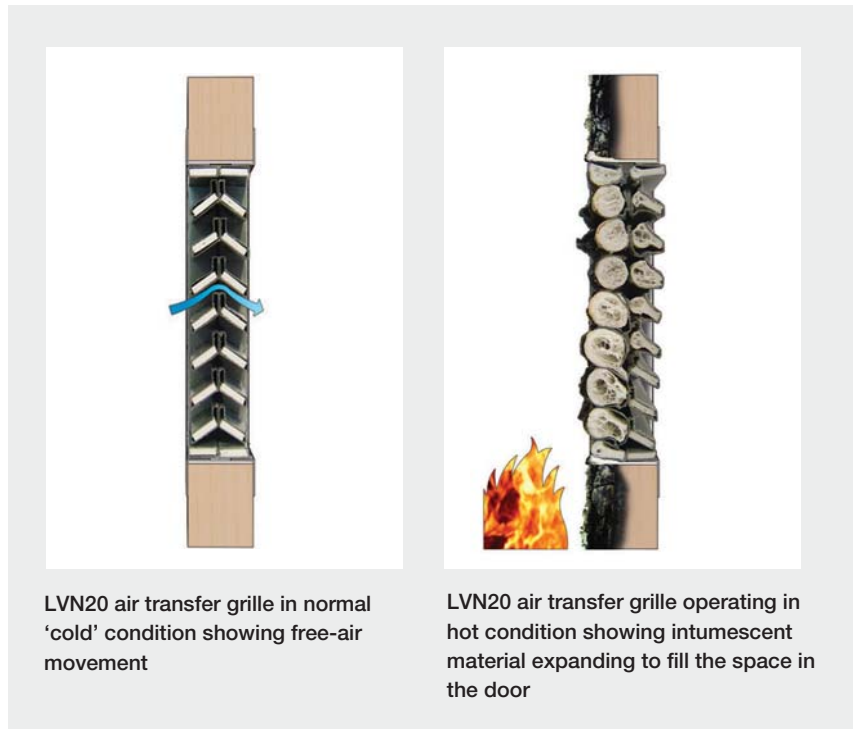

LVN20 air transfer grille in normal 'cold' condition showing free-air movement

LVN20 air transfer grille operating in hot condition showing intumescent material expanding to fill the space in the door

Lorient Smoke Control System

All ducts and airways in doors and walls can be protected against fire and hot smoke using Lorient intumescent air transfer grilles. However, these grilles will not prevent the passage of cold smoke which can be equally dangerous.

Damper / Shutter Assembly

To address this problem Lorient has developed a smoke damper assembly for use in conjunction with Lorient intumescent air transfer grilles.* The assembly comprises three slotted plates - two fixed plates sandwiching a central moving plate. The central plate is operated by a fail-safe motorised actuator. A movement of just 10mm changes the relative positions of the slots from "through flow" to "fully closed".

*Note: 'S' suffix added to product code. Shutter assembly cannot be added to standard air transfer grilles retrospectively.



Talkback damper in "through flow" position



Talkback damper in "fully closed" position

Control Systems for Smoke Damper Assemblies

The Talkback system can control up to sixteen dampers and features a status monitoring display.

Talkback Damper Control System

Most large buildings require a significant number of FD30S and FD60S fire doors (30 or 60 minute fire doors which also provide protection against cold smoke) within any one fire zone. These doors may be a considerable distance apart, or even on different floors.

The Talkback system has been designed to control up to sixteen damper assemblies from one centralised status monitoring unit. A unique 2-way communication system operates between the Damper Control and Monitor Unit (DCM) and the damper actuators. This facilitates a rapid assessment of the status of the installation and immediately identifies and locates any defective dampers.

Talkback is designed to give peace of mind to a building's occupants in that it:

- is fail-safe – the dampers will automatically close in the event of an alarm, power failure or damage to the wiring
- resets automatically – when the alarm is cancelled or power restored
- is self-testing – every 24 hours the dampers are automatically closed and opened to check they are working and to dislodge any dust and debris between the moving parts
- continuously monitors the status of each damper and displays this on the DCM
- is easy and quick to install – simple loop wiring is used and the damper units are supplied ready assembled and tested

- uses a safe 12V DC supply to open and close the dampers
- has been successfully tested in accordance with the requirements of the Electro Magnetic Compatibility and Low Voltage Directive and therefore bears the CE mark (copies of the relevant test reports are available on request).

Typical Installation of the Lorient Talkback System

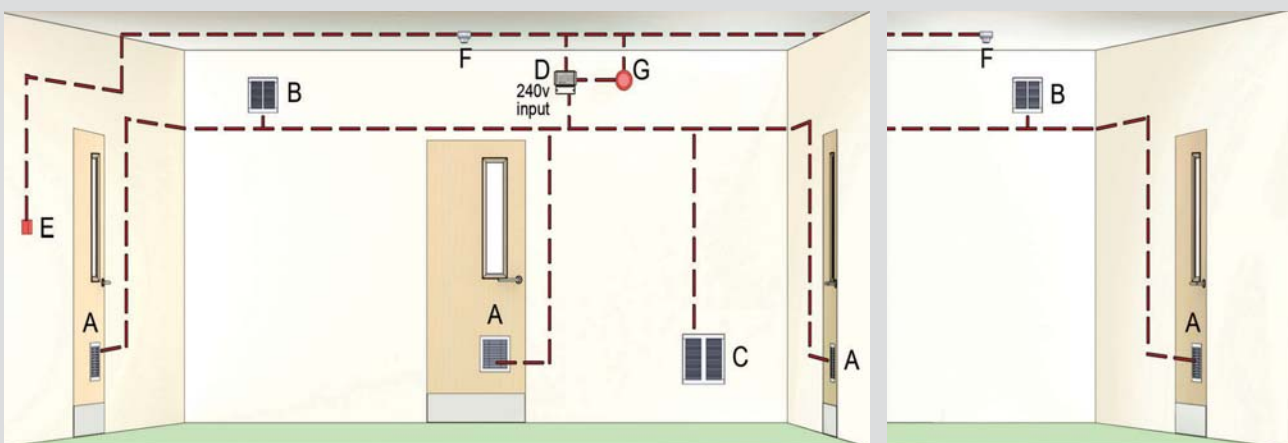

- A: Door mounted fire and smoke dampers
- B: End of duct fire and smoke dampers
- C: Wall mounted fire and smoke damper
- D: Power and monitor unit

- E: Fire point
- F: Smoke sensors
- G: Fire alarm

Performance

The dampers are supplied factory assembled and tested. When used in conjunction with Lorient fire containment intumescent air transfer grilles, tests have shown that they provide an effective barrier to fire and smoke at all temperatures.

It is therefore possible to create airways through fire resistant constructions and still meet the requirements of Building Regulations and the recommendations of BS 9999. The graphs show the estimated smoke leakage rates determined from tests carried out under the conditions of BS 476: Pt 31.1. The results have been interpolated to show the leakage rates using different sizes of damper/shutter assemblies.

Smoke leakage determined under the conditions of BS 476 Part 31.1 at a pressure differential of 25Pa. Door size 2023 x 822mm



Total smoke leakage of door leaf and damper / air transfer grille related to door perimeter

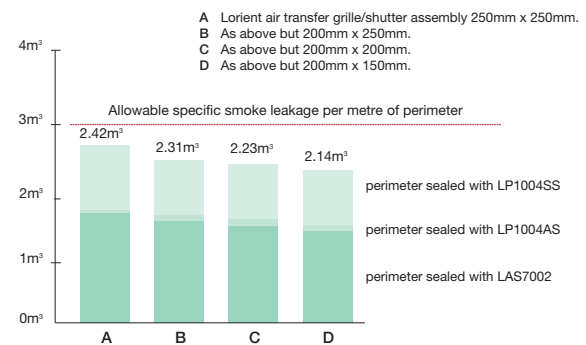

Installation

Lorient provides free technical support for the design, specification and installation of its smoke control systems.







Given the importance of the protection provided, it is recommended that Lorient is involved in the earliest stages of specification to ensure the most effective and economical system is specified and installed.

A comprehensive technical companion which covers the design and operation of Lorient smoke control systems is available; please consult our Technical Department.

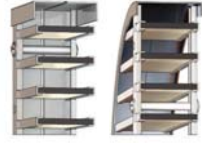

Fire and Smoke Resistant Dampers / Air Transfer Grilles

product solutions

| Product | LVN20 & LVN25 | LVV40 & LVC40 | LVH44 & LVHC44 | LVH54 |
|------------------------------|--|--|--|--|
| |   |   |   |   |
| | <p>two sizes of non-vision intumescent air transfer grille supplied in two halves to accommodate different door thicknesses</p> | <p>standard vision intumescent air transfer grille for walls, doors and rectangular or circular ventilation ducts</p> <p>suitable for use in some horizontal applications. Refer to Lorient's Technical Department</p> | <p>high performance steel vision intumescent air transfer grille for use in doors, walls, floors, ceilings and ventilation ducts</p> | <p>high performance stainless steel intumescent fire damper for use in ventilation ducts</p> <p>LVH54 is not currently tested in the horizontal plane</p> |
| Width: | 100mm - 600mm (in 50mm increments) | 100mm - 600mm (in 25mm increments) | 100mm - 600mm [†] (any size in between) | 100mm - 600mm [†] (nominal) in 50mm increments. Custom sizes also available |
| Height: | 100mm - 600mm (in 50mm increments) | 100mm - 600mm (in 25mm increments) | 100mm - 600mm [†] (any size in between) | 100mm - 600mm [†] (nominal) |
| Diameter: | | up to 600mm diameter (nominal to suit standard PVC pipes or steel ducts) | up to 600mm diameter (nominal to suit standard steel ducts) | |
| Thickness: | 2 pieces x 20mm or 2 pieces x 25mm | 40mm | 44mm | 54mm |
| Free area: | 30% approx. | 60% approx. (circular is different) | 60% approx. | 60% approx. |
| Can be used with: | integral steel, PVC or aluminium flanges no cover grille required | metal cover grille (optional) | metal cover grille (optional) NB: LVH44 and LVHC44 can be used in external applications | |
| Fitting: | screwed and bedded in Lorient intumescent sealant | screwed and bedded in Lorient intumescent sealant | screwed and bedded in Lorient intumescent sealant | screwed and bedded in Lorient intumescent sealant |
| Materials and Finish: | PVC, silver as standard also available in white | PVC, silver as standard | galvanised steel Note: [†] Larger apertures possible. Refer to Lorient's Technical Department | galvanised steel/stainless steel |

LVHCTD



duct mounted fire and smoke damper

Smoke Control System

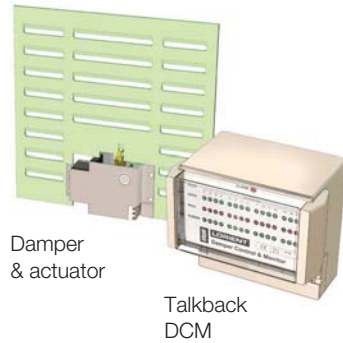

Damper & actuator

Talkback DCM

Talkback

Cover Grilles



optional cover grilles for walls, doors and ends of ducts

pressed steel and aluminium options available

weather louvre options available for use on external applications (refer to Lorient's Technical Department)

Flanges

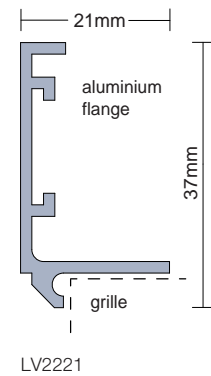
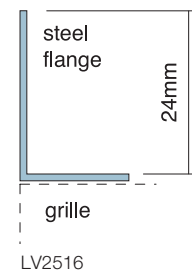
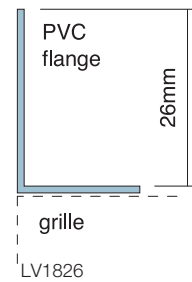

450mm

450mm (maximum)

standard sizes available are: 200mm – 600mm (in 50mm increments) Modular systems are available, please ask for details

sizes to suit standard dampers / air transfer grilles

larger sizes available (refer to Lorient for details)

30% approx.

30% approx.

NB: will change the free air flow characteristics of the air transfer grille

LVH44
LVH54

LVV40
LVH44
LVH20S

Refer to Lorient's Technical Department

NB: for special applications, the Lorient smoke dampers can be used on their own. Refer to Lorient's Technical Department

screw fixed

screw fixed

zintec steel

DCM off-white



pressed steel, white, silver, primer or mill

















Refer to Lorient's Technical Department

matching colours are available: aluminium, natural satin anodised / powder coated

The following pages show the levels of protection provided by Lorient fire resistant dampers / air transfer grilles when used in doors, compartment walls, ducts, floors and ceilings.

Use of symbols

-  indicates that the application detail shown provides protection against fire
-  indicates that the application detail shown provides protection against cold smoke
- 60** indicates in minutes the fire protection provided by the intumescent air transfer grille / fire damper

| level of protection | type of protection | vertical / horizontal | doors | walls | floors & ceilings | ducts | | | | |
|---------------------|--|-----------------------|--------------|-------------|-------------------|--------------|--------------|--------------|--------------|---------|
| 30 |  | vertical | LVN20 | page 13 | n/a | n/a | n/a | n/a | n/a | |
| | | vertical | LVN25 | page 13 | n/a | n/a | n/a | n/a | n/a | |
| | | vertical | LWV40/LVC40 | page 13 | n/a | n/a | n/a | n/a | n/a | |
| | | horizontal | n/a | n/a | n/a | n/a | n/a | n/a | n/a | |
| 60 |   | vertical | LVN20S | page 14 | n/a | n/a | n/a | n/a | n/a | |
| | | vertical | LVN25 | page 13 | n/a | n/a | n/a | LVH44 | page 17 | |
| | vertical | LWV40/LVC40 | page 13 | LWV40/LVC40 | page 15 | n/a | n/a | LWV40/LVC40 | page 17 | |
| | horizontal | n/a | n/a | n/a | n/a | LVH44/LVHC44 | page 16 | LVH44/LVHC44 | page 18 | |
| |   | vertical | LVN20S | page 14 | LWV40S | page 15 | n/a | n/a | n/a | n/a |
| 90 |  | vertical | LVH44/LVHC44 | page 13 | n/a | n/a | n/a | n/a | n/a | |
| | | horizontal | n/a | n/a | n/a | n/a | LVH44/LVHC44 | page 16 | LVH44/LVHC44 | page 18 |
| |   | vertical | LVH20S | page 14 | n/a | n/a | n/a | n/a | n/a | |
| 120 |  | vertical | LVH44/LVHC44 | page 13 | LVH44/LVHC44 | page 15 | n/a | n/a | LVH44/LVHC44 | page 18 |
| | | horizontal | n/a | n/a | n/a | n/a | LVH44/LVHC44 | page 16 | LVH44/LVHC44 | page 18 |
| |   | vertical | LVH20S | page 14 | LVH44S | page 15 | n/a | n/a | n/a | n/a |
| 180 |  | vertical | n/a | n/a | LVH44/LVHC44 | page 15 | n/a | n/a | LVH44 | page 18 |
| | | horizontal | n/a | n/a | n/a | n/a | LVH44/LVHC44 | page 16 | n/a | n/a |
| |   | vertical | n/a | n/a | LVH44S | page 15 | n/a | n/a | n/a | n/a |
| 240 |  | vertical | n/a | n/a | n/a | n/a | n/a | LVH54 | page 18 | |
| |   | vertical | n/a | n/a | n/a | n/a | n/a | LVHCTD | page 18 | |

LVN20 (for 44mm & 54mm)

For installation in lower half of door leaf

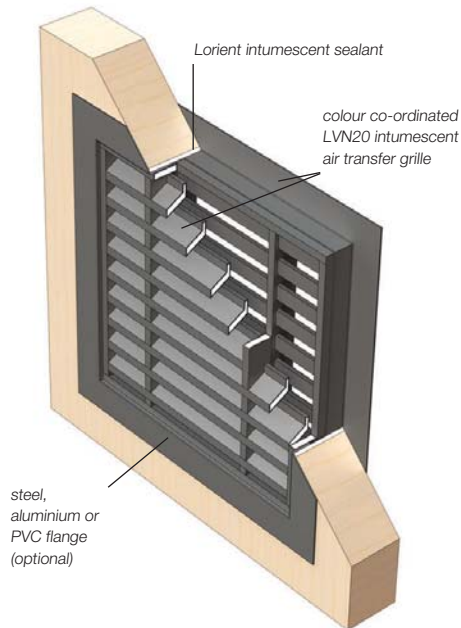

LVN25 (for 54mm only)

For installation in lower half of door leaf

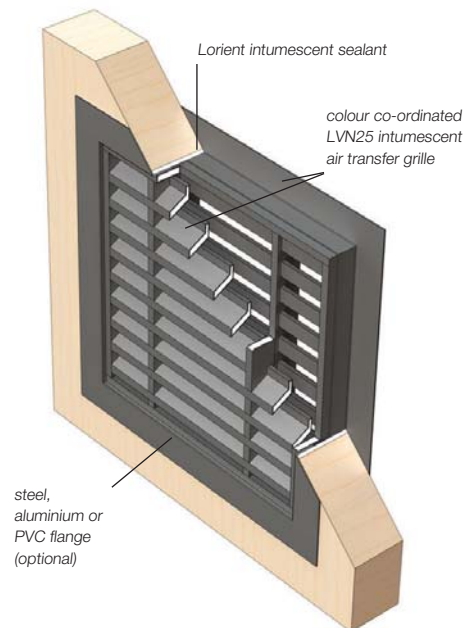

LVV40 & LVC40

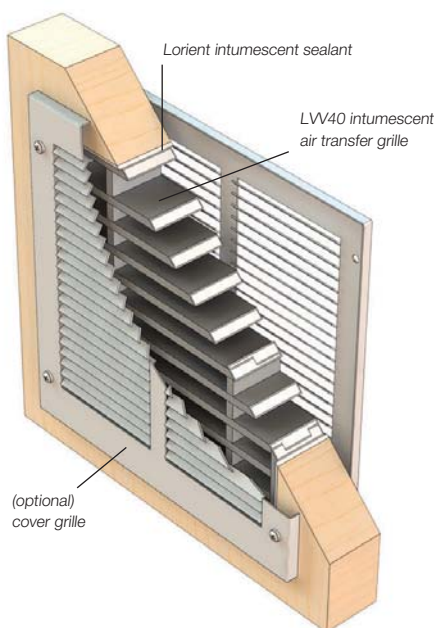

LVH44 & LVHC44

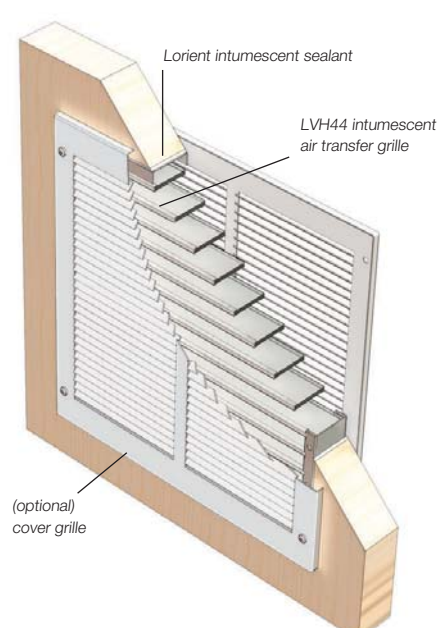

LVN20S – door thickness min. 44mm

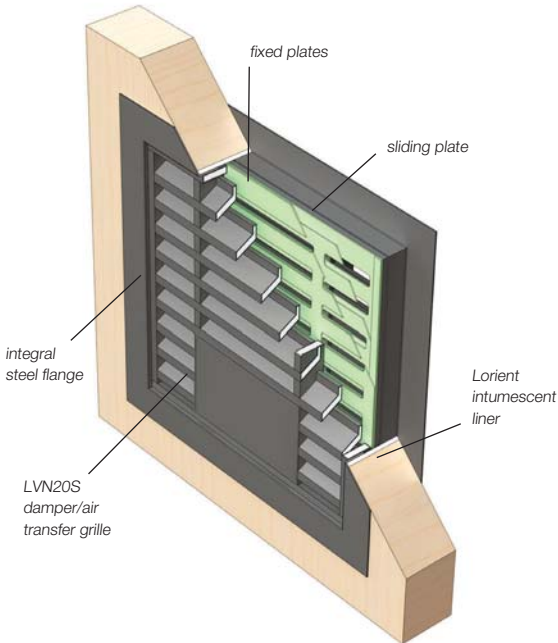

LVH20S – door thickness min. 50mm

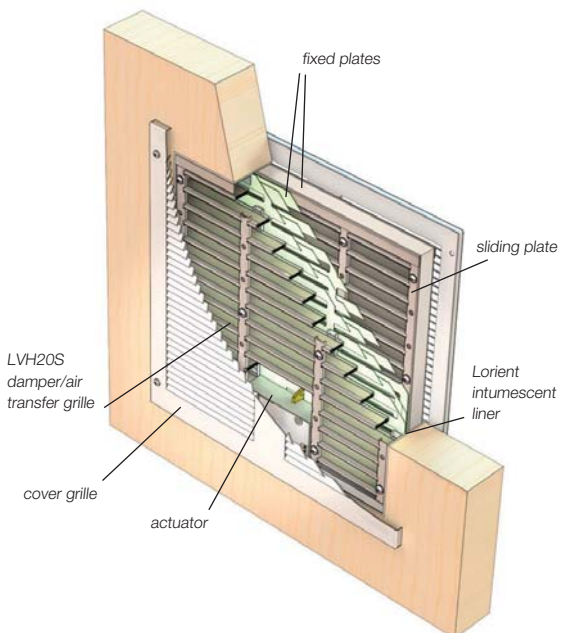

LVV40 & LVC40

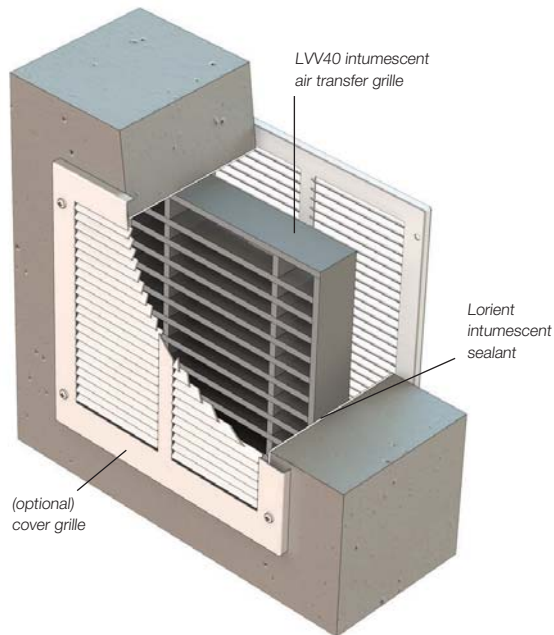

LVV40S – wall thickness min. 80mm

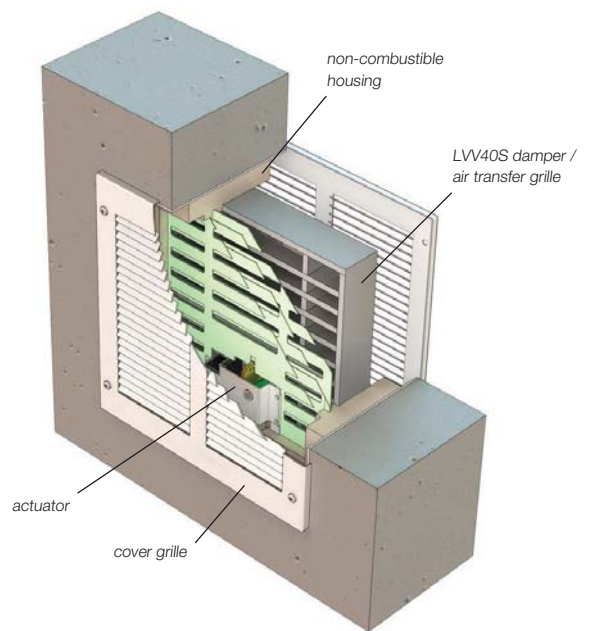

LVH44 & LVHC44

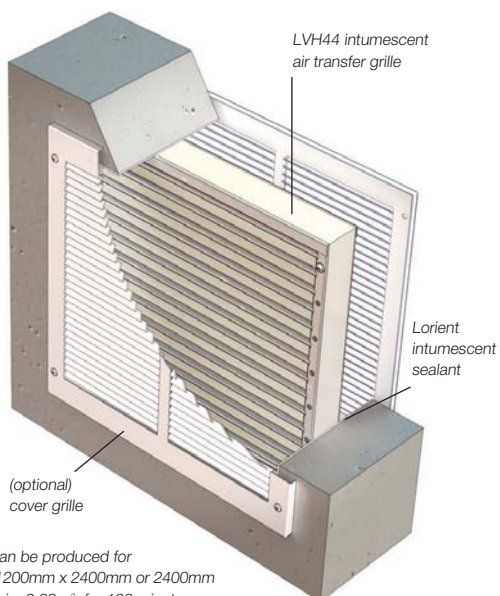

Note:
LVH44's can be produced for
apertures 1200mm x 2400mm or 2400mm
x 1200mm ie: 2.88m², for 120 minutes

Please refer to Lorient's Technical Department

LVH44S – wall thickness min. 80mm

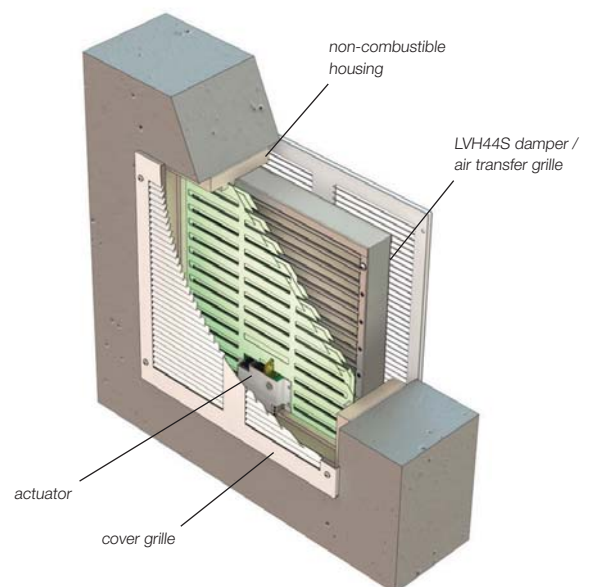

LVH44 & LVHC44 – floor thickness min. 50mm

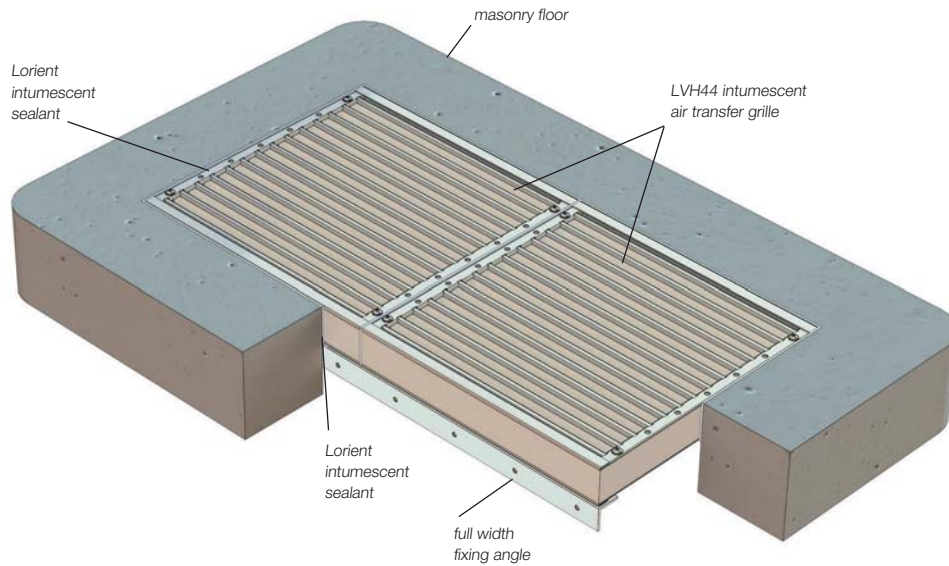

Note:
Modular installation shown. The maximum size for this method of installation is 1200mm x 600mm. Please consult Lorient for larger sizes

LVH44 & LVHC44 – ceiling thickness min. 50mm

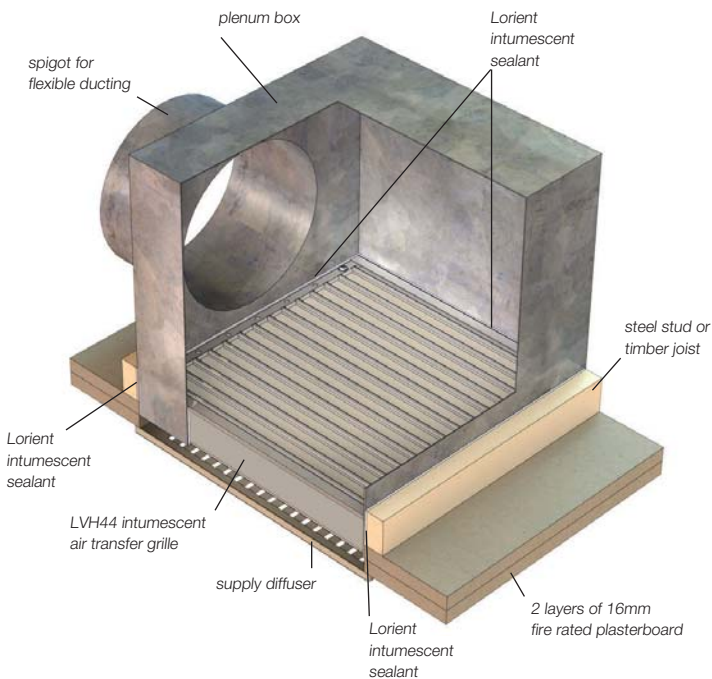

Note: The maximum size for this installation is 600mm x 600mm

LVV40

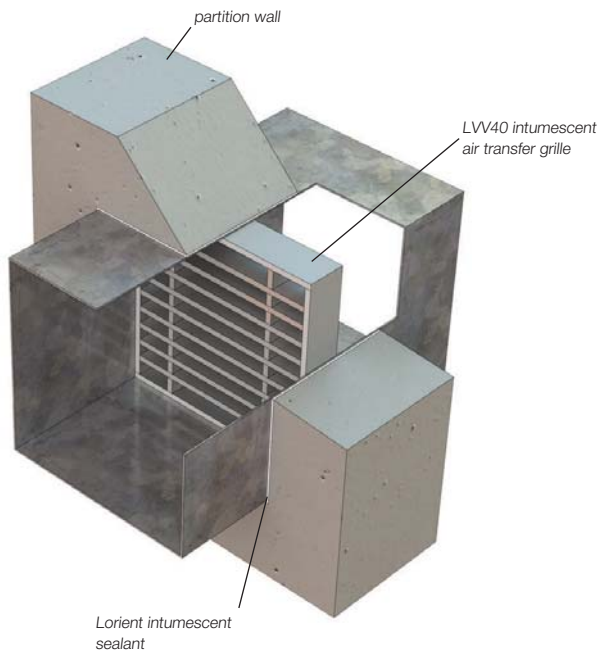

LVC40

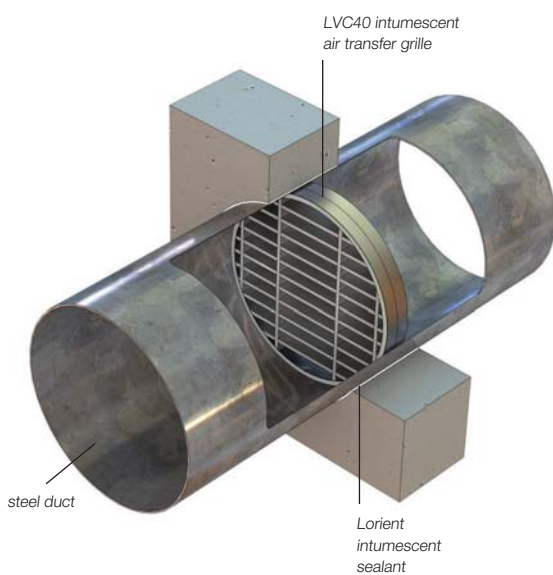

LVC40

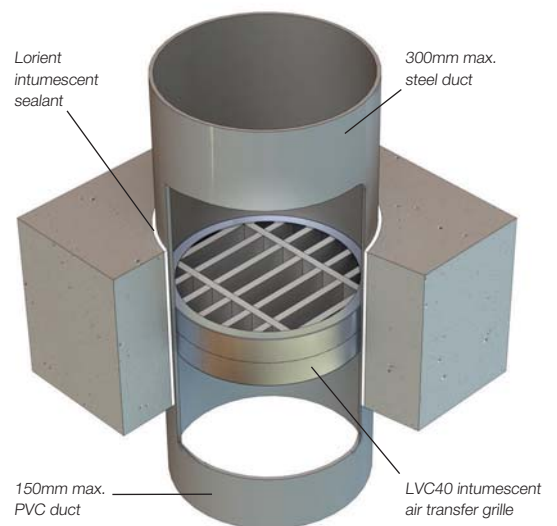

LVH44

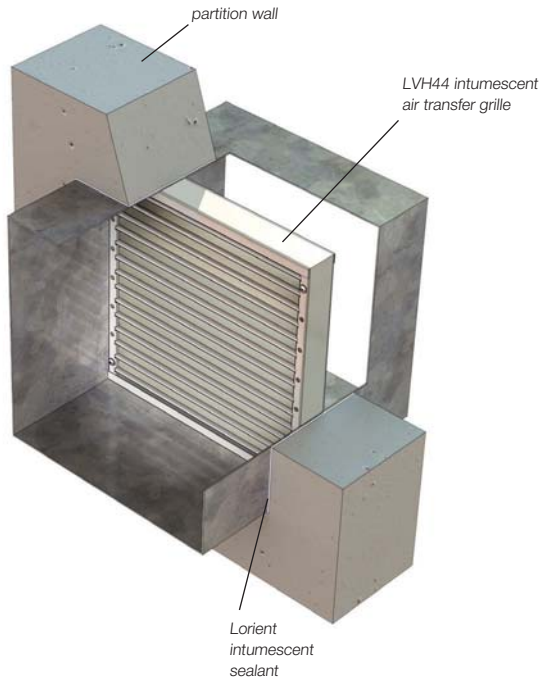

LVHC44

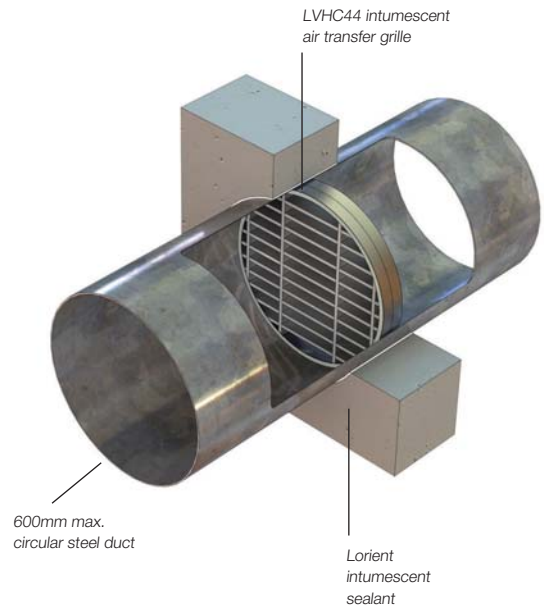

LVHCTD

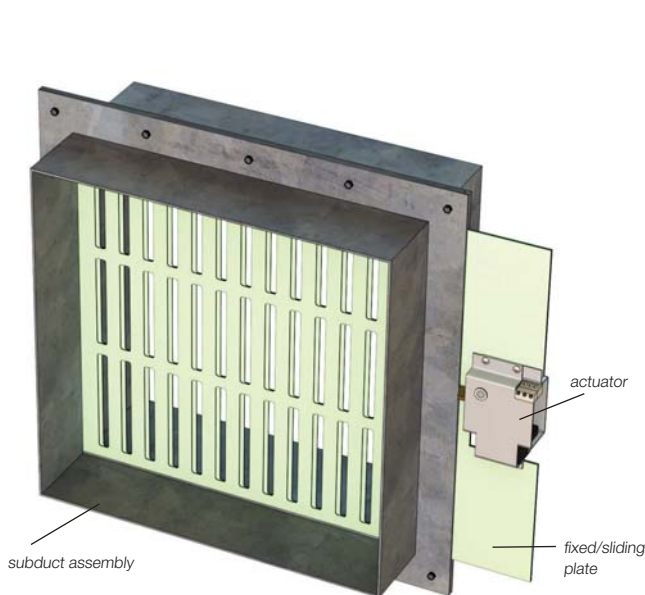

LVH54

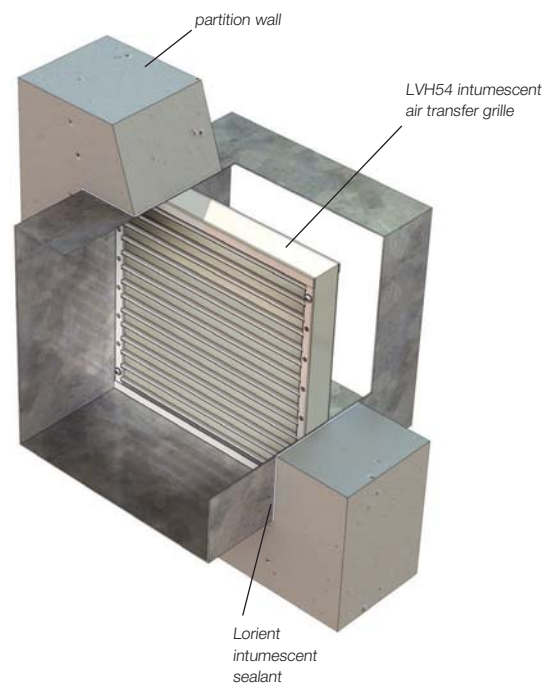

Sealant

Lorient produces intumescent sealant for bedding in dampers / air transfer grilles.

- When exposed to fire, it will expand to many times its original volume while maintaining adhesion.
- Suitable also for sealing gaps between fire resistant walls and floors, between conduits and walls/floors and between fire resistant walls and structural supports.



Finishes

Fire door assemblies and dampers / air transfer grilles are often chosen for their appearance as well as their performance.

Standard Colours



Silver (0701)

White (0303)

Note: The limitations of the printing process means the colours and finishes shown here may not be exactly the same as the grilles supplied. Lorient can supply samples to assist colour matching.

Special Colours

Lorient offers a colour matching service and can usually formulate a precise colour match on receipt of appropriate details such as a BS or RAL colour reference or a material sample. A modest set up charge is made to cover costs, please ask for further details.

PVC/steel flanges and air transfer grilles can be colour matched.

Additional information

Technical References



BS EN ISO 9001:2008
Certificate No. Q6104

Lorient is quality assured under the disciplines of BS EN ISO 9001: 2008.

Accreditation to this standard is a guarantee that we conduct our business to the complete satisfaction of our customers with regard to design solutions, manufacturing consistency and management procedures.

In addition, this internationally recognised standard for quality management generates customer confidence and eliminates the risk of poor performance. Regular audits of our company procedures are undertaken by qualified BSI staff to ensure ongoing compliance with all aspects of the Standard.



BS EN ISO 14001:2004
Certificate No. EMS 541906

Lorient has attained the BS EN ISO 14001:2004 accreditation for environmental management, making us the first seal manufacturer to have achieved this important award. This internationally recognised standard represents that we have demonstrated our commitment to responsible environmental behaviour, including prevention of pollution, control and reduction of waste, and ongoing monitoring and improvement of our environmental performance. Achieving ISO 14001 is just one part of our ongoing commitment to operate in a sustainable way.

Handling and Storage

No special precautions are required when handling Lorient dampers / air transfer grilles but they should always be treated with care. The products do not fall within the scope of COSHH regulations.

Lorient dampers/air transfer grilles should be stored away from heat, in the dry, and protected from impact damage.

Maintenance

Lorient intumescent air transfer grilles, including those positioned behind cover grilles, will require periodic cleaning with a damp cloth.

The use of intumescent materials means there are no moving parts. The product is trouble free in operation and easy to maintain – periodic testing is unnecessary.

Trade Associations

Lorient is proud to be a member of the following associations.

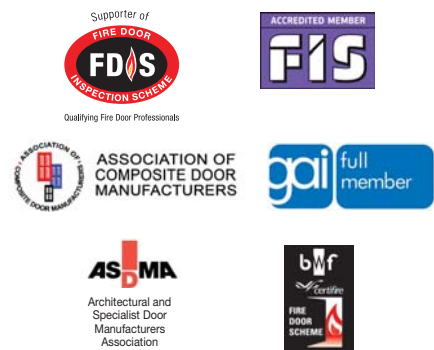

Made in Britain

We are proud to have been granted the prestigious Made in Britain marque for our products that are designed and manufactured at our main facility in the South West of the UK.



Intellectual Property

© 2016 Lorient Polyproducts Ltd – this brochure is protected by copyright and neither the drawings nor the text may be reproduced or transmitted in any form without prior consent from Lorient. Lorient products described in this brochure are protected by patents and design registrations in Great Britain and other countries.

We are committed to continually enhancing and improving our product range. We reserve the right to change product specifications from time to time without prior notice. E&OE.

Continuing Professional Development Seminars

We offer three fully-accredited CPD seminars. Impartially presented by knowledgeable speakers, the seminars are structured to be technically informative, and give practical advice.



Performance Door Design: The Basics of Sound Reduction

Effective acoustic containment helps to improve the quality of the built environment, preserving privacy as well as excluding unwanted noise. With changing regulations, it's essential to be up to date with the relevant requirements and the implications for door assemblies.

Our acoustic CPD seminar covers:

- the nature of sound, examining airborne transmission of sound;
- regulatory requirements and British Standards that relate to acoustic performance;
- test procedures and interpretation of test reports;
- effective design of door assemblies for acoustic performance, including door construction and the influence of sealing systems;
- design conflicts between acoustic performance, durability and ease of operation of the door;
- independent accreditation.

The Role and Performance of Fire and Smoke Resisting Door Assemblies

The importance of fire and smoke resisting door assemblies is illustrated by the 322 annual deaths in fire tragedies in the UK alone. Apart from the human toll, property losses each year approach £2.52 billion.

Our fire and smoke containment seminar covers:

- hard facts concerning deaths, injuries and property damage caused by fire and smoke;
- regulatory requirements for fire and smoke resisting door assemblies;
- the nature and behaviour of smoke;
- effective design of door assemblies for smoke containment, including the threshold gap;
- design conflicts between fire containment, smoke containment, durability and ease of operation of the door;
- independent accreditation.

The Regulatory Reform (Fire Safety) Order 2005 and its implications for fire doors

The RRO consolidated 70 pieces of legislation; shifted responsibility for fire safety management; abolished the Fire Safety Certificate; established the Fire Risk Assessment and created major change in legal liability.

Our RRO CPD seminar covers:

- an overview of the RRO;
- product solutions;
- the dangers of fire and smoke;
- the importance of fire doors – including installation and maintenance.

Our CPD materials have been independently verified and certified by the RIBA as CPD approved. A certificate for 1 hour's CPD will be provided, which contributes to Continuing Professional Development requirements.

If you're interested in booking a seminar, please contact our Marketing department or email cpd@lorientuk.com.

We continue to lead the way in research and development: As a company we have over 35 years' experience, so our experts are well equipped to listen, help and advise you on your acoustic, smoke and fire containment needs.

comprehensive support

Technical Support

We're happy to provide specialist advice on acoustic, smoke and fire protection for refurbishment and new build projects. If you need assistance, you can call our Technical Services team.

Alternatively, we can arrange a site visit to get a clearer idea of your needs and how we can help you. We also provide copies of test reports and samples where needed; and can give guidance on how best to meet Building Regulations and Standards.

We also offer a professional and expert fire door inspection service. Our Certificated Fire Door Inspectors are fully qualified under the Fire Door Inspection Scheme (FDIS); and have been assessed by Exova Warringtonfire, an independent third party. Certificated to carry out the inspection of your building's fire doors and prepare a detailed survey and report on the condition and function of the fire doors on your premises.



Qualifying Fire Door Professionals

Web Support

Our website features a comprehensive range of supporting documents covering the entire range of products, including installation guides and CAD drawings. All of our brochures and product sheets are also available for download, together with copies of certification and specification texts.

Online acoustic search tool

Our acoustic search tool on our website gives you quick and easy access to a wide range of tested acoustic sealing systems on a variety of popular door constructions & configurations.

www.lorientuk.com/acousticsearch

The tool allows users to select a specific decibel rating; along with door configuration, fire door rating, doorset type etc to filter the results. The 'Acoustic Search' tool is updated frequently with Lorient's ever-expanding portfolio of test evidence. If you're looking for high performance or specialist applications – please contact us on **+44 (0) 1626 834252**, there may be some additional configurations we haven't presented.

Customisation

If you have a particular requirement which isn't covered by the applications in this brochure, we may be able to supply an existing non-standard item, or even develop a customised solution for you. Utilising in-house expertise, bespoke products are created to your requirements; from a functional or aesthetic perspective, or both.

Lorient's dedicated Technical Services team supports and works as part of your design team, offering informed product advice and guidance on regulatory requirements and standards.



Call our Technical Services team on
01626 834252
www.lorientuk.com

www.lorientgroup.com



LorientPolyproducts



@LorientUK



Lorient



lorientuk



UK and Europe

Tel: +44 (0) 1626 834252

Fax: +44 (0) 1626 833166

email: mktg@lorientuk.com

USA

Tel: +1 859 252 7441

Fax: +1 859 381 1241

inquiries@lorientna.com

Hong Kong

Tel: +852 2505 0328

Fax: +852 2505 0332

email: sales@lorienthk.com

Singapore

Tel: +65 6270 1279

email: sales@lorient.com.sg

Dubai

Tel: +9714 883 7206

Fax: +9714 883 7207

email: sales@lorientgulf.ae

Australia

Tel: +61 (02) 99076221

email: sales@lorient.com.au



Lorient Polyproducts Ltd
Endeavour House
Fairfax Road
Heathfield Ind Estate
Newton Abbot
Devon TQ12 6UD UK