

IS8091 si Automatic Threshold (Door Bottom) Seal Heavy Duty



An automatic threshold (door bottom) seal which is spring-loaded to lift clear of the floor as soon as the door is opened by a few millimetres. It requires no power connection. It is face-fixed and has an aluminium cover plate to conceal fixing screws and presents an exceptionally smooth external aspect. Plastic end plates are supplied. Completed over 1,000,000 operating cycles without failure. Tested for acoustic performance in accordance with BS EN ISO 140-3: 1995. It also meets the smoke leakage performance requirements of BS 5588 when tested in accordance with BS 476 Pt 31.1 and AS 1530.7.

Location

Single swing doors.

Use with

Any perimeter seal (6000 or 7000 series).

Min/max gap size

1mm/15mm.

Seal material

Black or grey silicone rubber.

Standard lengths

335mm, 435mm, 535mm, 635mm, 735mm, 835mm, 935mm, 1035mm and 1135mm.

Each length can be cut to the next size down.

The 335mm can be cut back to 255mm.

Acoustic performance

Weighted Sound Reduction Index (Rw): 35dB.

Sound Transmission Class (STC): 35dB.

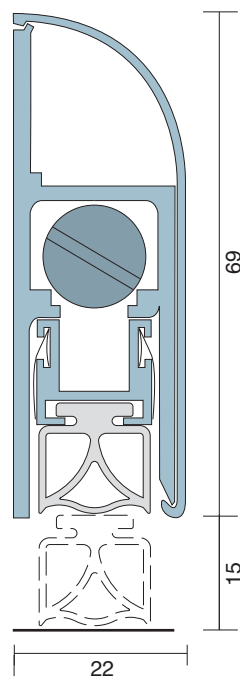
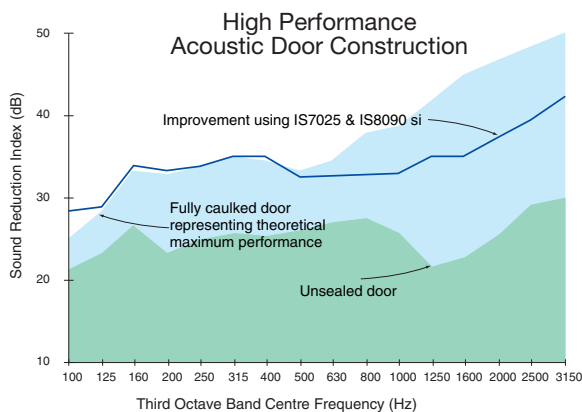

IS8091 si

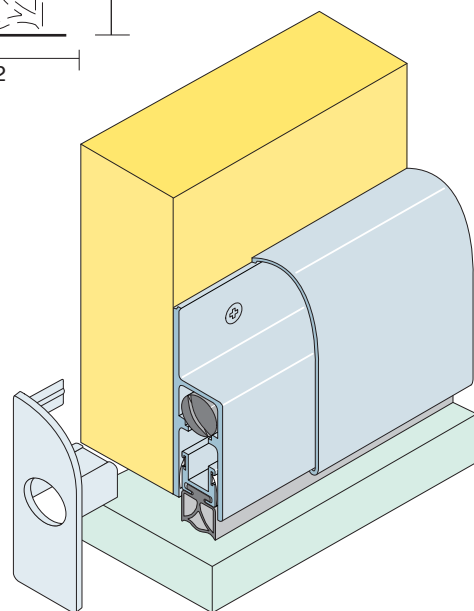

Fixing

Fixing screws are supplied, fixing holes are pre-drilled.

Adjustment

Self-levelling on uneven surfaces – can be adjusted independently of the fixing screws.

Finishes

Silver anodised aluminium, grey silicone rubber gasket, grey end caps.

Bronze anodised aluminium, black silicone rubber gasket, black end caps.

Special colours can be supplied using a powder coated finish for additional aesthetics.