

**IS8090 si Automatic Threshold (Door Bottom) Seal**  
 Heavy Duty

An acoustic automatic threshold (door bottom) seal which is spring-loaded to lift clear of the floor as soon as the door is opened by a few millimetres. It requires no power connection. It is face fixed or can be semi-mortised and end plates are supplied. Tested for reliability, the seal completed 1,000,000 cycles without failure. Tested in accordance with BS EN ISO 140-3:1995. See Acoustic Sealing Systems for Door Assemblies manual for further details. It also meets the smoke leakage performance requirements of BS 5588 when tested in accordance with BS 476 Pt 31.1 and AS 1530.7.

**Location**

Single swing doors.

**Use with**

Any perimeter seal (6000 or 7000 series).

**Min/max gap size**

1mm/15mm.

**Seal material**

Black or grey silicone rubber.

**Standard lengths**

335mm, 435mm, 535mm, 635mm, 735mm, 835mm, 935mm, 1035mm and 1135mm.

*Note: Each length can be cut to the next size down.*

*The 335mm can be cut back to 255mm.*

**Fixing**

Fixing screws are supplied, fixing holes are pre-drilled (plastic end plates are supplied).

**Adjustment**

Self-levelling on uneven surfaces – can be adjusted independently of the fixing screws.

**Acoustic performance**

Weighted Sound Reduction Index (Rw): 29dB.

Sound Transmission Class (STC): 28dB.

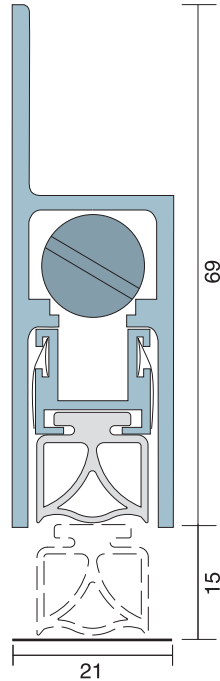

IS8090 si

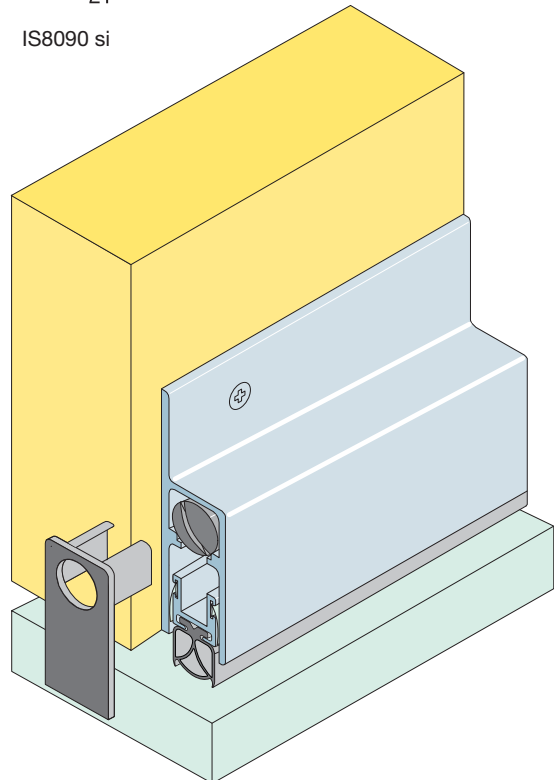
**Finish**

Silver anodised aluminium with grey silicone rubber gasket, grey end caps.

Bronze anodised aluminium with black silicone rubber gasket, black end caps.

