

IS8020 si Automatic Threshold (Door Bottom) Seal Heavy Duty

An automatic threshold (door bottom) seal which is spring-loaded to lift clear of the floor as soon as the door is opened by a few millimetres. It requires no power connection. It can be semi-mortised or face fixed and has an aluminium top cover plate which conceals fixing screws and presents an exceptionally smooth external aspect. Plastic end plates are supplied for the face-fixed version. Completed over 1,000,000 operating cycles without failure. Tested for acoustic performance in accordance with BS EN ISO 140-3: 1995.

Location

Single swing doors.

Use with

Any perimeter seal (6000 or 7000 series).

Min/max gap size

1mm/15mm.

Seal material

Black or grey silicone rubber.

Standard lengths

335mm, 435mm, 535mm, 635mm, 735mm, 835mm, 935mm, 1035mm and 1135mm.

Note: Each length can be cut to the next size down.

The 335mm can be cut back to 255mm

Acoustic performance

Weighted Sound Reduction Index (Rw): 35dB.

Sound Transmission Class (STC): 35dB.

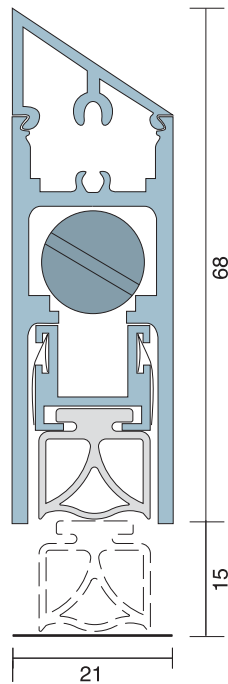
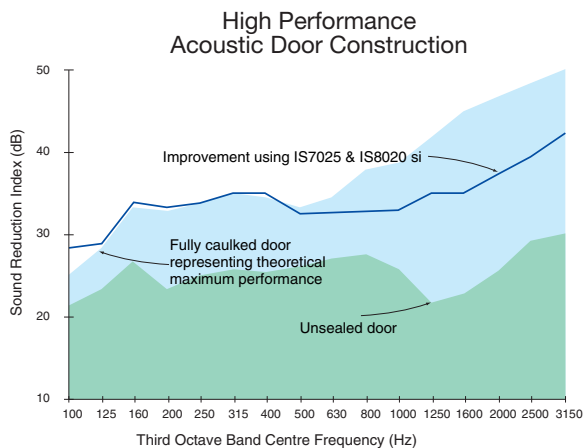

IS8020 si

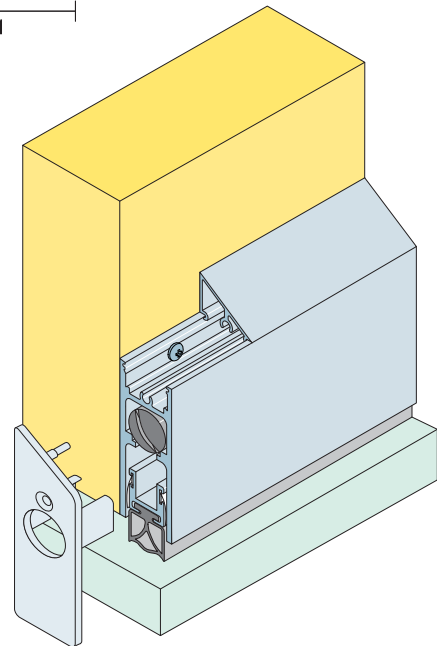
Fixing

Fixing screws are supplied, holes should be drilled at time of fixing.

Adjustment

Self-levelling on uneven surfaces – can be adjusted independently of the fixing screws.

Finishes

Silver anodised aluminium, grey silicone rubber gasket, grey end caps.

Bronze anodised aluminium, black silicone rubber gasket, black end caps.