

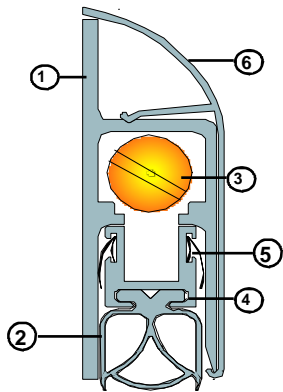

IS8091si

Fitting Instruction

Automatic Door Bottom Seal



Length 35mm

WARNING

Do not cut the seal before the hand of the door or seal location has been determined.

DESCRIPTION OF CONTENTS

- Aluminium carrier (1)
- Silicone gasket (2)
- Adjusting screw (3)
- Internal carrier (4)
- Smoke fins (5)
- Aluminium cover plate (6)
- Two end caps
- Striker button (drawing pin)
- Bag of screws
- Fitting instructions

TOOLS REQUIRED FOR INSTALLATION

- Tape measure
- Saw (power or hand)
- Screw driver
- 3.5mm drill bit
- Drill (power or hand)
- Knife
- Pencil or marker

REVERSING HAND OF SEAL

STEP 1

Remove the aluminium cover plate and the self-tapping screw from the front face.

STEP 2

Pulling on adjusting screw, remove the inner assembly from the housing (ensure not to disturb the sequence of components).

STEP 3

Replace the inner assembly into the opposite end of the seal.

STEP 4

Secure inner assembly by re-fixing self-tapping screw into the other hole location at the other end of the housing.

STEP 5

Check for correct operation before cutting to size.

STEP 2 Illustration

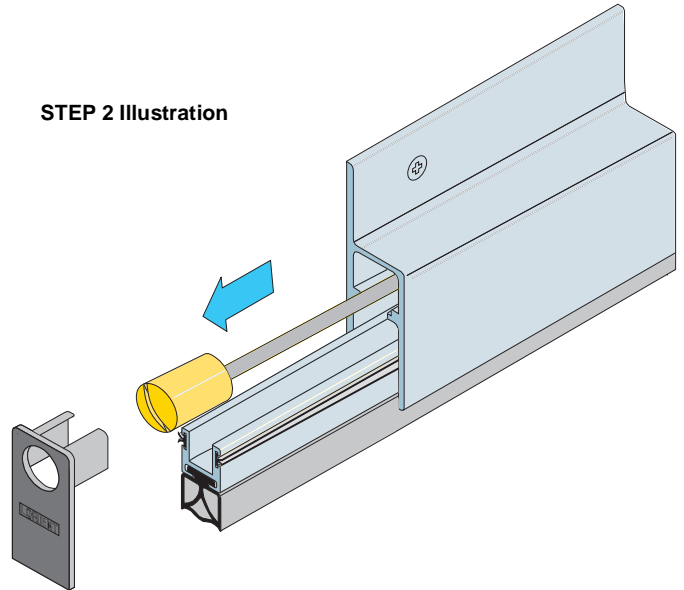

STEP 3 Illustration

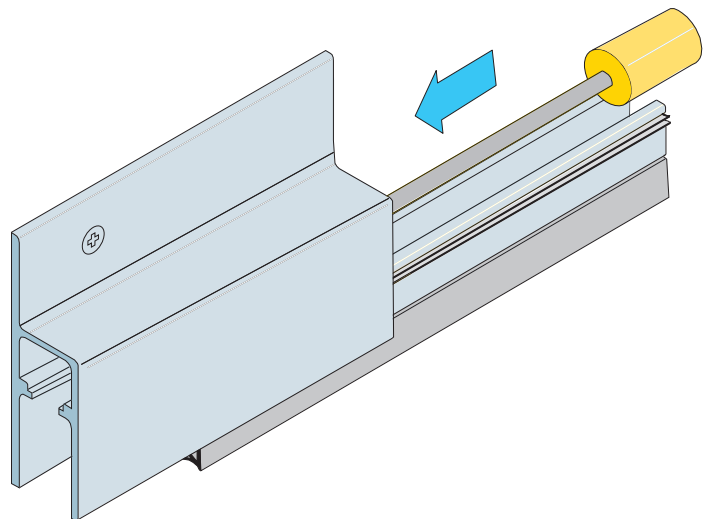

**INSTALLATION DETAIL****STEP 1**

Remove the seal from the packaging and measure the distance between the door stops.

STEP 2

Pull back the gasket and using a saw, cut the aluminium section to the desired length, less 6mm allowing for the adjusting screw operation (2mm hinge side) and end caps (2mm each end of seal).

NB: When cutting seal to length, shorten inner carrier section by a further 3mm at the end opposite the adjusting screw to allow free vertical movement of the seal.

STEP 3

Cut gasket to required length using a sharp knife.

STEP 4

Position the seal at the bottom face of the door, allowing a maximum 15mm gap (minimum 5mm) between the door bottom and the sill.

(See Figure 1)

STEP 5

Screw fix using screws provided, and refit the cover plate.

STEP 6

For timber frames, position the striker button on the jamb where the adjusting screw meets the door jamb.

STEP 7

'Push-fit' plastic end plates into position.

STEP 8

Close the door and observe the seal movement.

STEP 9

If the seal requires adjustment to make even contact with the sill, pull and turn the adjusting screw anti-clockwise to increase seal movement and clockwise to reduce seal movement (a turn at a time), until the desired seal is achieved.

We recommend the IS8091si automatic door bottom seal be fitted with a Lorient Integrity™ 7000 series perimeter seal and a 4000 series threshold plate.

IMPORTANT – Ensure that the installation of this product does not impede the opening or closing of the door. It is recommended to check the adjustment of the door seal periodically to ensure the door assembly to which it is fitted, closes and latches properly.

The seal may be removed for periodic cleaning or replacement of a worn gasket, without removing the door leaf from its frame.

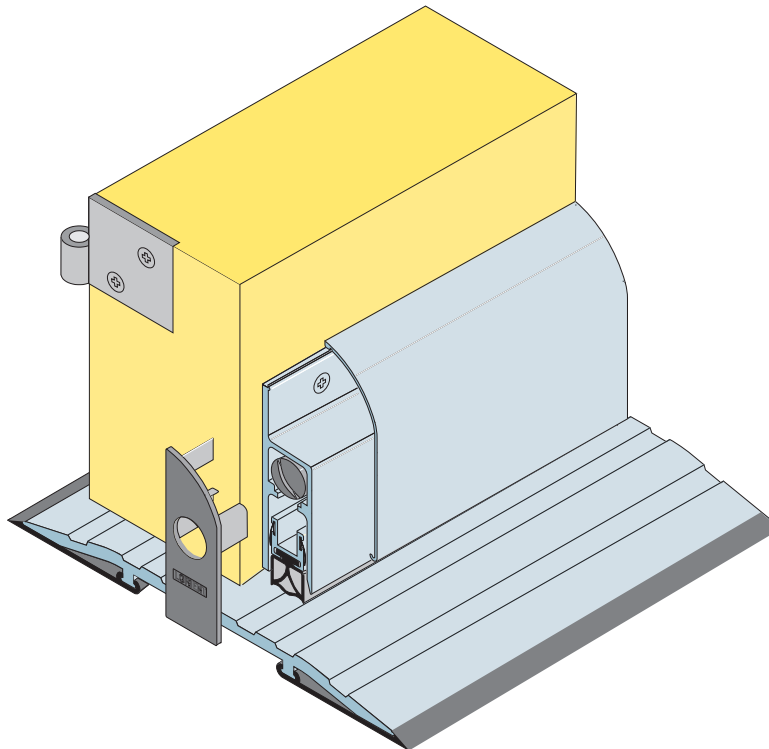
OTHER INTEGRITY™ ARCHITECTURAL SEALS INCLUDE:

- Door Perimeter Seals
- Door Bottom Seals
- Automatic Door Bottom Seals
- Threshold Plates
- Brush Seals
- Magnetic Seals

Contact your nearest Lorient office for further details.

NOTE

Recommendations as to methods for use of materials and construction details are based on the experience and knowledge of Lorient and are given in good faith as a general guide and service to designers, contractors and manufacturers.

Lorient reserves the right to make alterations or delete any installation detail without prior notice.

CUT BACK SIZES

Do not cut the seal shorter than the lengths indicated below or this will affect the normal operation of the internal mechanism.

335mm	cuts to	255mm
435mm	cuts to	255mm
535mm	cuts to	436mm
635mm	cuts to	536mm
735mm	cuts to	636mm
835mm	cuts to	736mm
935mm	cuts to	836mm
1035mm	cuts to	936mm
115mm	cuts to	1036mm

AUSTRALIA
 Lorient Australia Pty Ltd

QLD: (+61-7) 3635 5000
 NSW: (+61-2) 9907 3844
 VIC: (+61-3) 9785 2688

ASIA PACIFIC—Hong Kong
 Lorient Pacific Limited

Tel: (+852) 2505 0328

EUROPE—UK
 Lorient Polyproducts Limited

Tel: (+44-1626) 834 252